



# HAWKER

# LEVEL CONTROL SYSTEMS

## Signal Conditioner Type 990

Application Wiring Diagram for Intrinsically Safe Pressure Transmitters Type HPTX23/IS to be read in conjunction with Type 990 Installation and Setting up Instructions.

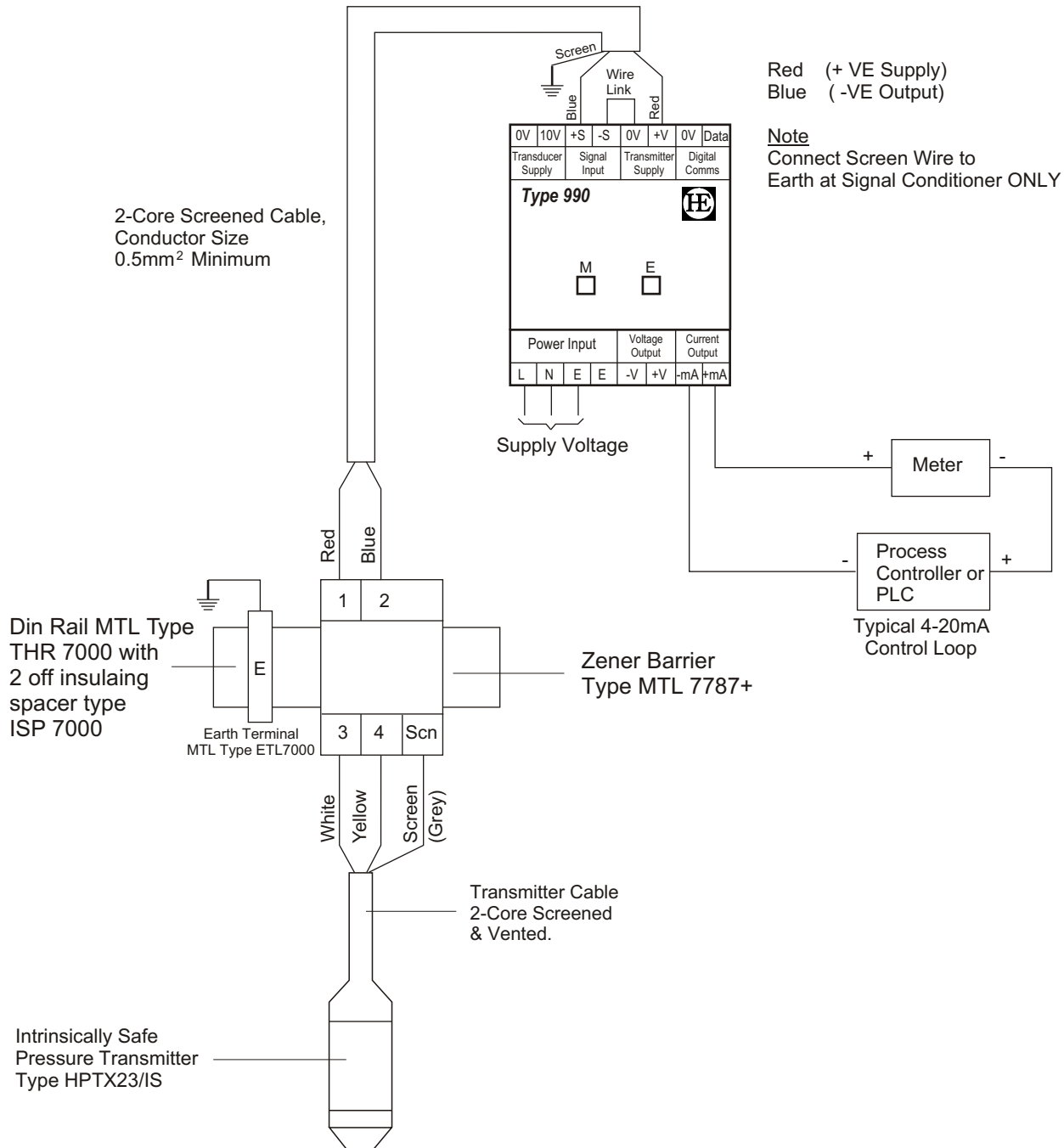

This product has been designed and complies to the relevant standards as listed in its certificate of conformity. The installer/user must ensure system compliance because of continuing development we reserve the right to change the specification without notice

### HAWKER ELECTRONICS LTD

57, The Avenue,  
Rubery Industrial Estate,  
Birmingham, B45 9AL, England  
Telephone :+44(0)121-453-8911 Fax: +44(0)121-453-3777  
E.mail: info@hawker-electronics.co.uk



FM 10000



W D 77  
Issue A  
May 06  
D974.cdr