



HAWKER

LEVEL CONTROL SYSTEMS

Type E22

Medium Duty Electrode Holder

For use with all level controllers and alarms operating in aqueous (conducting) liquids i.e. water, acids, chemical effluent, beverages etc.

- 3/4inch B.S.P.P connection
- Corrosion resistant holder
- Suitable for 12mmØ electrodes
- Electrodes available for most aggressive liquids

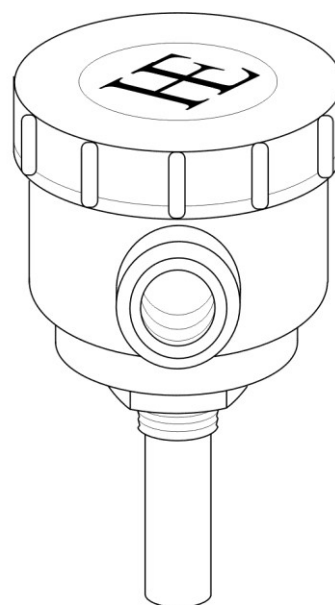

The **Type E22 Electrode Holder** is suitable for conducting liquids such as water and chemicals, manufactured in corrosion resistant Polypropylene and complete with back-nut.

The holder will accept 12mmØ electrodes typically in 316L Stainless Steel, Hasteloy C, Monel, Titanium supplied plain or plastic coated. Plastic coated electrodes are PPA coated WRAS approved No 1711505.

Maximum shipping length is 3 metres, couplers are available for lengths in excess. Steady brackets are advisable every 2m if turbulence is present.

Electrode length is calculated from the underside of the body (add 24mm).

A pressure type version is available on request. ATEX and IECEx approved models are available for use with P8/IS level controllers.

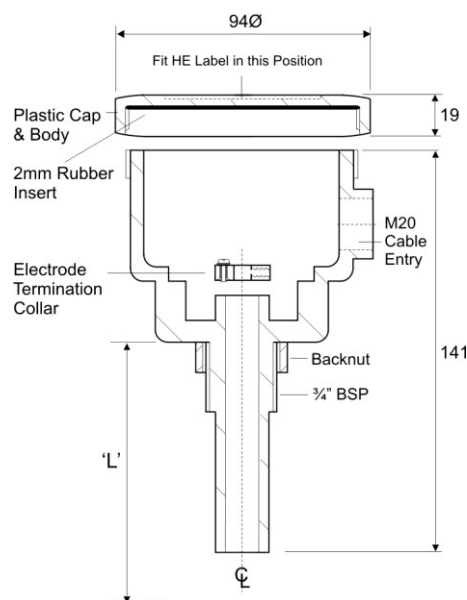

This product has been designed and complies to the relevant standards as listed in its certificate of conformity. The installer/user must ensure compliance. Because of continuing development we reserve the right to change the specifications without notice.

HAWKER ELECTRONICS LTD.

57 The Avenue,
Rubery Industrial Estate,
Birmingham B45 9AL, ENGLAND
Telephone: +44 (0)121-453-8911 Fax: +44(0)121-453-3777
email: info@hawker-electronics.co.uk www.hawker-electronics.co.uk



FM 10000

BRITISH MADE