



HAWKER LEVEL CONTROL SYSTEMS

Heavy Duty Electrode Holder Type E12/P Pressure Tight Version

E12/P Electrode holders are suitable for sewage, water and effluent applications. Moulded in Phenolic (SR4007) for high strength and chemical resistance. Similar to HPE8 but with tall powder coated aluminium alloy cap providing an electrode depth adjustment of up to 335mm.

Supplied with: Stainless Steel termination support collar, Brass clamping collar (to provide a pressure tight connection tested to 3 metres submersion for 8 hours), two rubber gaskets, also Stainless Steel nuts and bolts (to secure cap to the base).

Electrodes are available in Stainless Steel 316L or galvanised Mild Steel, with either type available in bare metal or black PPA plastic coated finish.

Maximum shipping length of electrode

a) Stainless Steel – 3m

Stainless Steel electrodes are available threaded with a coupler to make up lengths greater than 3m (this service will incur additional charges).

b) Galvanised – 3.2m

Galvanised is supplied threaded both ends and c/w one coupler to make up lengths greater than 3.2m.

PPA plastic coating is WRAS approval No: 1610508.

Electrode steady brackets (Type 85) are advisable every 3 metres.(material Stainless Steel and UPVC).

Electrode length is calculated from the underside of the flange plus 92mm.

Rubber bungs are available to insert in the electrode end to prevent ingress of fluid.

Plastic touch-up paint for electrodes is available.

ATEX APPROVED models are available (Type HPE12/P/IS) for use with P8/IS level controller.

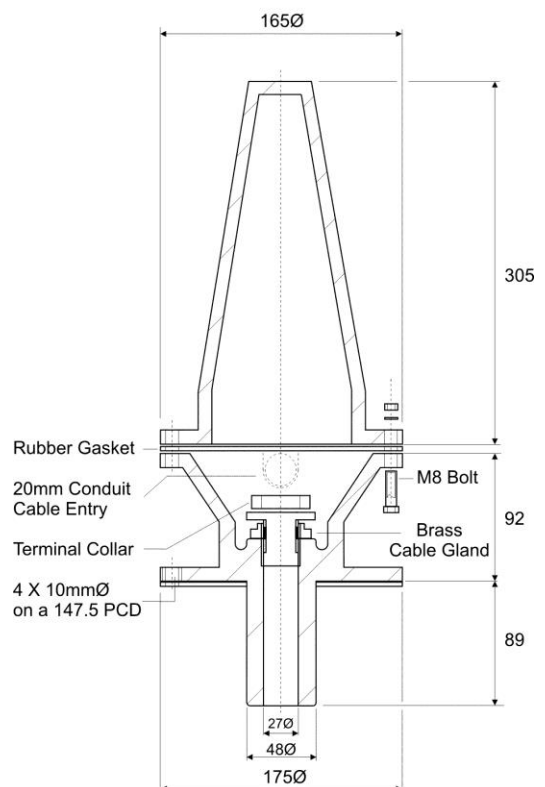
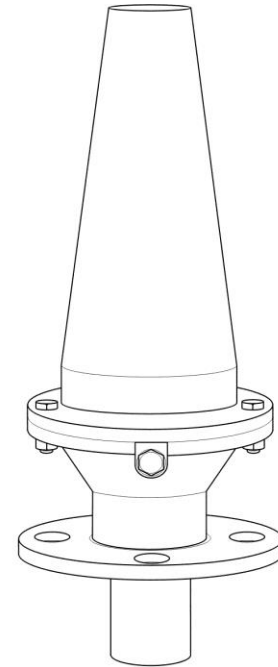

This product has been designed and complies to the relevant standards as listed in its certificate of conformity. The installer/user must ensure compliance. The crossed out bin symbol, placed on the product, reminds you of the need to dispose of the product correctly at the end of its life. Because of continuing development we reserve the right to change the specifications without notice

HAWKER ELECTRONICS LTD.

57 The Avenue,
Rubery Industrial Estate,
Birmingham B45 9AL, ENGLAND
Telephone: +44 (0)121-453-8911 Fax: +44(0)121-453-3777
email: info@hawker-electronics.co.uk www.hawker-electronics.co.uk



FM 10000