

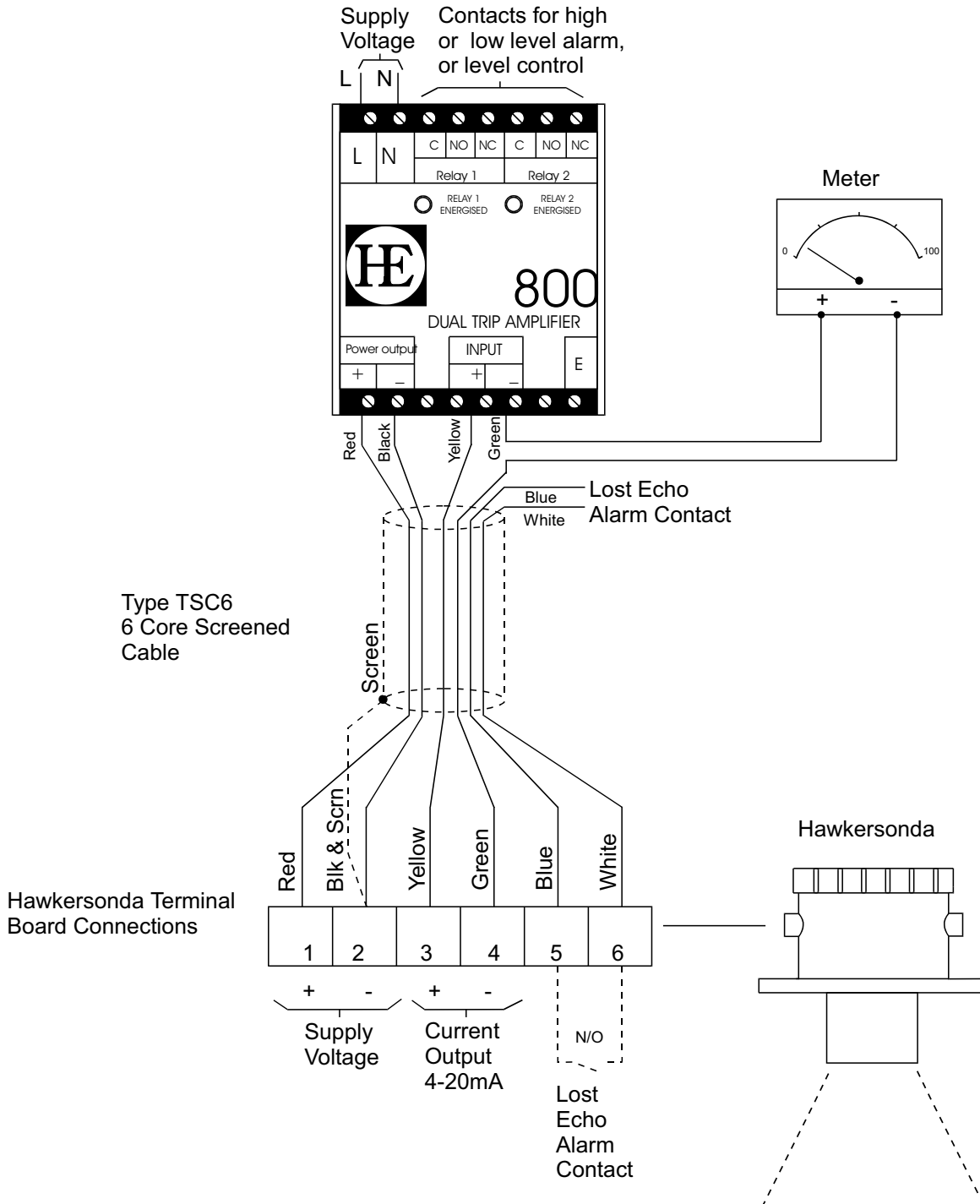

HAWKERSONDA

Wiring Diagram for Type 800 Dual Trip Amplifier and Meter used with Hawkersonda Level Transmitter, to be read in conjunction with Hawkersonda & Type 800 installation & setting up instructions.



This product has been designed and complies to the relevant standards as listed in its certificate of conformity The installer/user must ensure system compliance
Because of continuing development we reserve the right to change the specifications without notice.

HAWKER ELECTRONICS LTD.

57, The Avenue,
Rubery Industrial Estate,
Birmingham, B45 9AL, ENGLAND
Telephone : +44(0)121-453-8911 Fax : +44(0)121-453-3777
e mail: info @ hawker- electronics.co.uk



WD 4
Issue B
Feb 02
D405.cdr