



HAWKER

LEVEL CONTROL SYSTEMS

Type HFL6

- * Ecologically Friendly
- * Polypropylene Housing
- * Suitable for Diesel Oil
- * Available in 5, 10, or 20m lengths
- * Moveable Weight
- * Simple to Install

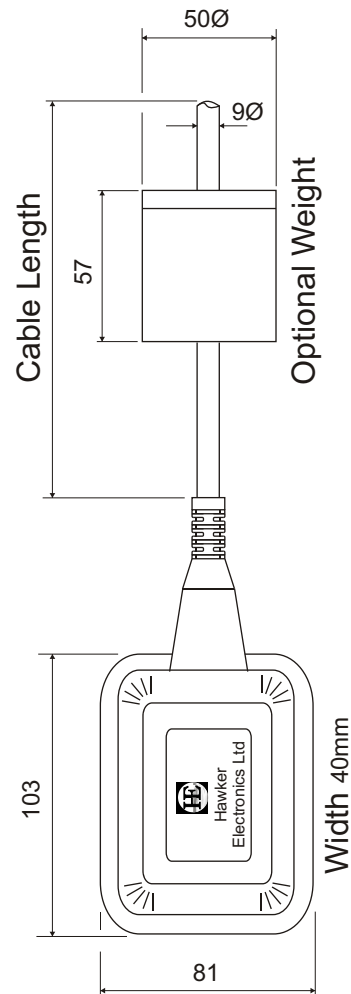

Operating Principle

The **HFL6** is a plastic float switch moulded to a polyurethane 3 core cable for use in diesel oil

The float is suspended from its cable just below the surface of the liquid so that wave effect is negligible. When the liquid reaches or leaves the float, it tilts and operates its mechanical switch, the angle of the operation being 45° , this can stop or start a pump or operate an alarm.

Two floats are required for control between two levels. They are provided with external ballast to ensure correct tilt operation in any direction.

Although the floats are designed to switch mains, it is preferable to interpose a low voltage power supply with relay such as the Hawker 118 or AC1 wall mounting units which switch 5 amps.

The single pole double throw microswitch is controlled by a rolling ball and is axially mounted in line with the ballast weight. As the switch tilts contacts are either made or broken to start or stop a pump etc.

If excessive turbulence is expected the cable should be either supported or clipped to the side of the vessel.



HAWKER TECHNICAL SPECIFICATION

Technical Data

Float chamber material:	Polypropylene
Cable:	3x0.75mm ² Pur Polyurethane
Contact rating:	5A @ 50V 50Hz (non inductive) (use an interposing level controller to comply with health and safety regulations).
Max submerged depth:	20 metres
Min operative depth:	350mm
Max operating temp:	70°C
S.G. Of liquid:	0.9 to 1.3
Weight:	0.7Kg/5m, 1.2Kg/10m, 2.2Kg/20m

Ordering Information

HFL6/05m:	5 metre cable
HFL6/10m:	10 metre cable
HFL6/20:	20 metre cable

Optional mounting Brackets:	Type 75/HFL galvanised MS bracket with UPVC cable clamp Type 75/SS/HFL Stainless Steel bracket with UPVC cable clamp
-----------------------------	---

Connection Diagrams

Hawker Electronics Level Controller Connections

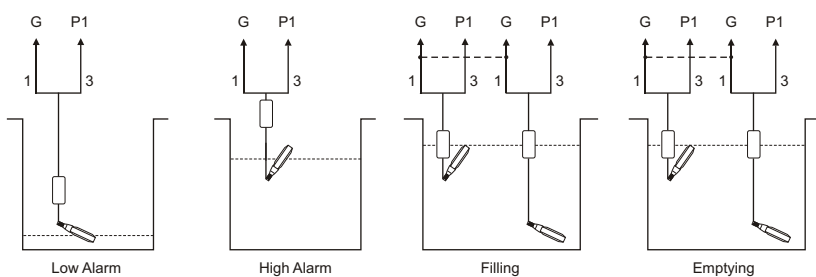

Cable Core Colour		Single Float		Dual Float			
		Low Alarm	High Alarm	Filling	Emptying		
Brown (Common)	1	✓	✓	✓	✓	✓	✓
Blue	2						
Black	3	✓	✓	✓	✓	✓	✓

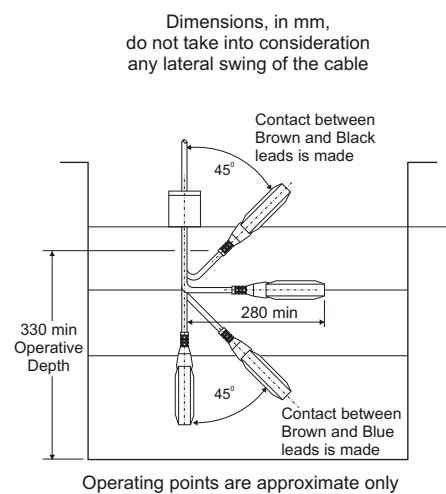

Because of continuing development we reserve the right to change the specifications without notice

HAWKER ELECTRONICS LTD.

57 The Avenue,
Rubery Industrial Estate,
Birmingham B45 9AL, ENGLAND
Telephone: +44 (0)121-453-8911 Fax: +44(0)121-453-3777
email: info@hawker-electronics.co.uk www.hawker-electronics.co.uk



FM 10000



BRITISH MADE