



Discrete Level Control
for Free flowing powders
& Non-conducting liquids

THE MAGIFLEX SYSTEM

- ★ A probe operated system • No moving parts
- ★ Low power requirements
- ★ Supersensitive • Detects at tip of probe only & ignores build up on body
- ★ Selectable input & output time delays
- ★ Low cost • Stable & simple to install
- ★ Detects thro' non-metallic container walls
- ★ Oil/Water interface detection
- ★ Suitable for most low bulk density & aerated materials

LOW COST of OWNERSHIP

The MAGIFLEX System

Based on the well proven Magicap system the MAGIFLEX comprises a digital controller to supply power to the low voltage sensing probes which are in mounted in a vessel at the level where detection is required. The sensing probe type MP1 replaces the Magicap probe KP1, the controller UC1 replaces the controller KC2, and the controller UC1/P replaces the Magicap controller KC4.

Sensing occurs when materials touch or leave the tip of the probe.
The signal is transmitted to the control unit to actuate the relay's voltage free contacts.

The probes can be used in virtually any point level application. Due to the Supersensitivity adjustment probes can be set to detect (or ignore) foam on liquids, detect blockages of aerated product in pipes and interface detection (e.g. Oil/Water). As only the tip of the probe is sensitive product contamination is ignored.

A wide range of products are available in sizes from a standard 98mm insertion length to flexible cable versions. Connection can be 1¼" BSP or sanitary triclover.

The controllers can be used in single sensor (point) or dual sensor (latched) mode to give alarms or On/Off control. Variable time delays can be set for each sensor and in-built diagnostics ensure reliable operation expected from a Hawker product.

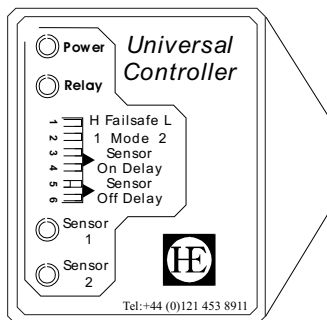

UC1/P Universal Controller for Panel Mounting

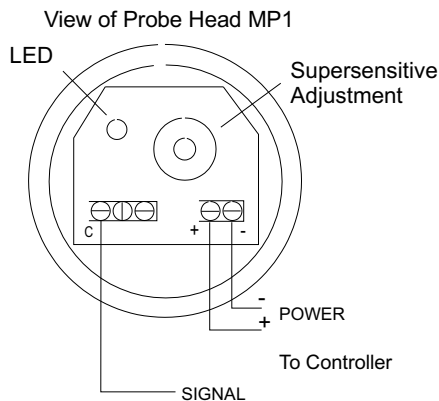

MP1 Probe with Cap removed to show Adjustment Pot & LED

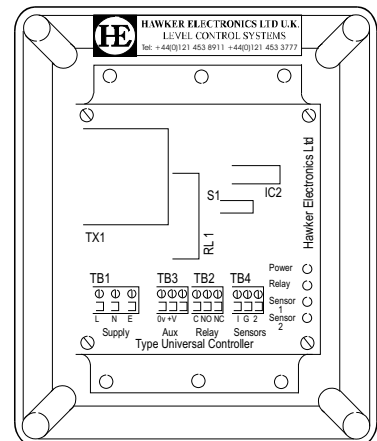

UC1 Universal Controller for Wall Mounting

TYPICAL APPLICATIONS

Alum	Coal	Food Products	Ice Cream	Paraffin	Sugar
Aggregates	Cat Litter	Foundry Sand	Lime	Perchlorethylene	Sulphur
Alcohol	Cocoa Beans	Flour	Limestone	Peat	Sucrose
Acetone	Coffee Beans	Fullers Earth	Lubricating Oils	Polypropylene and PVC	
Adhesives	Cement	Fertilizer	Latex	Potatoes	Tea
Acid	Carbon Tetrachloride	Frozen Vegetables	Molasses	Peanuts	Toluene
Ash	Creosote	Fish Food Pellets	Methylated Spirits	P.V.C. Glue	Turpentine
	Chocolate	Fibre Insulation	Maize	Plastic Granuals	Tetrachloride
	Ceramic Powders	Fish Food Pellets	Metals	Refractory Materials	Wax
Bone Meal	Clay				Wood Shavings
Black Nickel	Corn	Glucose	Oats	Sand	Wheat
Barley		Glacial Acetic Acid	P.F. Ash	Sawdust	Washing Powders
Bran	Distilled Water	Glycerine	Potato Chips	Soda Ash	Whiskey
Bitumen	Diesel Oil	Gravel	Petrol	Spent Grains	
Bread Crumbs	Dry Salt			Sodium Carbonate	Xylene
Benzene	Edible Fats			Starch	

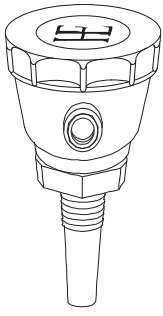

MP1 standard probes for mounting on the top or the side of a vessel. Polypropylene housing contains terminals, supersensitivity potentiometer & LED. temp range -20⁰ to 80⁰ C max pressure 500 psi @ 20⁰ C polypropylene tube sensing at the tip only . (optional Ryton tube) connection 1¼" BSP. weatherproof to IP67.

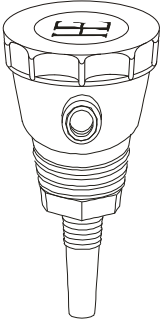
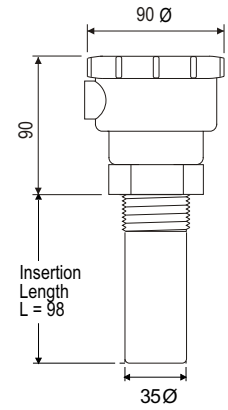

MP8 high temperature probe for mounting on top or side of a vessel. Polypropylene housing contains terminals, supersensitivity potentiometer & LED. temp range -20⁰ to 200⁰ C max pressure 500 psi @ 20⁰ C Ryton tube sensing at the tip only. Connection 1¼" BSP. weatherproof to IP67. .

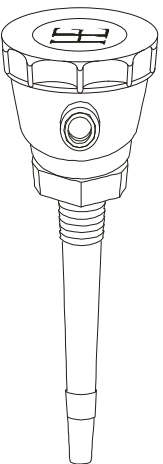
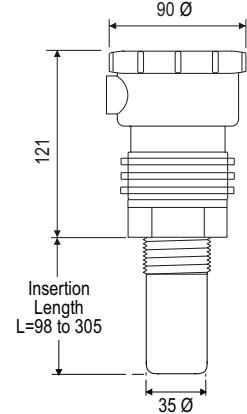

MP1/Extended and **MP1/Adjustable** probes for top mounting. Polypropylene housing contains terminals, supersensitivity potentiometer & LED. temp range -20⁰ to 80⁰ C max pressure 500 psi @ 20⁰ C polypropylene tube sensing at the tip only .(optional Ryton tube) connection 1¼" BSP. weatherproof to IP67. Customised insertion lengths are available from 98 to 2500mm.

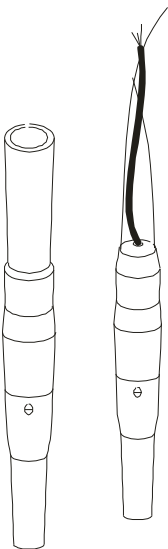
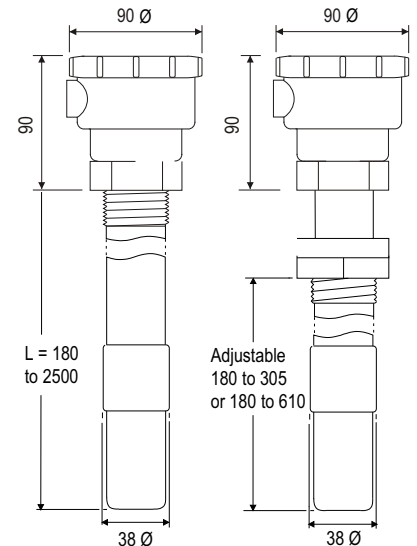

MP7 & MP7/E Flexible suspended probe for free suspension or screwing onto conduit. Ideal for silos or restricted head room. 316L S/S housing contains supersensitivity potentiometer & LED 3-core flexible cable encapsulated into housin. Connection via strain wire or ¾" BSP thread. Weatherproof

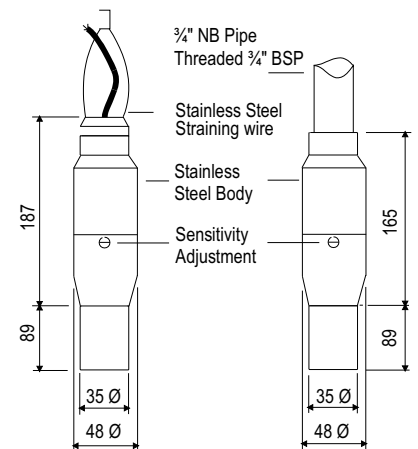

Probes are available with sanitary fittings and metal housings in Aluminium or Stainless Steel, Brackets, Sockets and Backnuts are available

Related Hawker Products

Flexicap Continuous Capacitance: Data Sheet No 254

Flexilevel 2 Digital Controller: Data Sheet No 288

Flexicap 4-20:

Data Sheet No 278

Sondaloop (Ultrasonic)

Data Sheet No 283

Technical Data

Universal Controller (UC)

Supply:	230V/115V AC 50Hz 24V DC reverse polarity protected (selected at works)
Consumption:	0.35W @ 24V DC (no load) 1W @ 24V DC (under load) 5W @ 230V AC (under load)
Inputs:	2 MP1 Probes
Max Input Resistance:	2,000 ohms
Dip Switch:	User Adjustable
Input Timer: (on delay)	0, 5, 15, 120 sec's by dip switches
Output Timer: (off delay)	0, 5, 15, 120 sec's by dip switches.
Accuracy:	Better than +1sec or -1sec on 120 sec's range
Repeatability:	100%
Fail to Safe:	High or Low
Modes:	Single or Dual switched inputs
Outputs:	Relay Volt Free SPCO contacts 5A @ 230v resistive LED'S Yellow = Power On Red = Relay Energised Green = Sensor 1 Active Green = Sensor 2 Active
Aux Supply: (from mains unit)	15-20V DC @ 50mA Unregulated (Internal 100mA resettable fuse).
Operating Temp:	-10°C to +60°C
Weight	
UC1/P:	215 gms
UC1:	850 gms
Diagnostic:	Flashing Input L.E.D.'s
Protection	
UC1/P:	IP20
UC1:	IP65

Dimensions

UC1/P for Panel Mounting

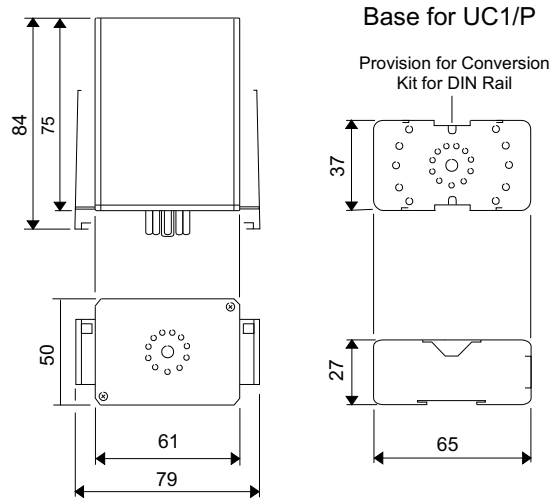

UC1 for Wall Mounting

Polycarbonate enclosure with clear lid

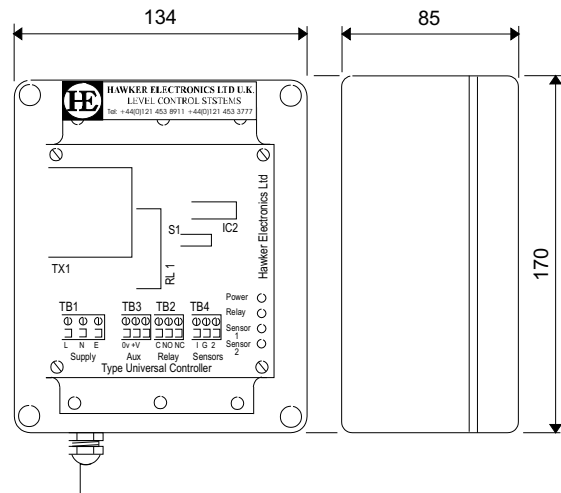

Probe Ordering Information

MODEL	DESCRIPTION
MP1	Standard L = 98mm
MP1/E/305	Extended L = 305mm
MP1/E/610	Extended L = 610mm
MP1/ADJ/305	Adjustable L = 180 to 305mm
MP1/ADJ/610	Adjustable L = 180 to 610mm
MP1/E/X	Extended any dimension between 178 to 2500mm
MP7	Flexible cable version with strain wire
MP7/E	Flexible cable version with 3/4" BSP thread
MP8	High temperature L = 98mm with Ryton tube
UC1/P	Panel mounting Controller
UC1	Wall mounting Controller
/Ryton	Optional Ryton tube
201	Strain wire for MP7
202	3-core cable for MP7 & MP7/E
204	Stainless Steel backnut 1 1/4" BSP
206	Stainless Steel socket 1 1/4" BSP

Types of HAWKER Capacitance Probes

MP1 the MAGIFLEX system employs up to two of these probes, which are powered by a Universal Controller Type UC1 or UC1/P. This also provides latching facility for dual probes, and the volt free contacts. It is generally powered by AC (although it will also operate on DC)

LS1 is a stand alone probe with built in relay. It is generally powered by nominal 24V DC (although it will also operate in 12V AC). Since there is no latching facility incorporated, if dual probe operation is required, it is necessary to interpose a Universal Controller Type UC1 or UC1/P See also Data Sheet No 224

The two probes are similar in appearance, but may be distinguished by the colour of the label on the termination head, LS1 has a Yellow label & the MP1 has a Red label.

For a full list of HAWKER products and application notes visit our web site at www.hawker-electronics.co.uk

Because of continuing development we reserve the right to change the specifications without notice.

HAWKER ELECTRONICS LTD.

57, The Avenue, Rubery Industrial Estate,
Birmingham B45 9AL, ENGLAND

Telephone : +44(0)121-453-8911 Fax : +(0)121-453-3777

e mail: info@hawker-electronics.co.uk Data Sheet No 297 Iss B



FM 10000

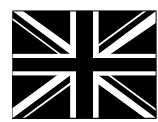

BRITISH MADE