

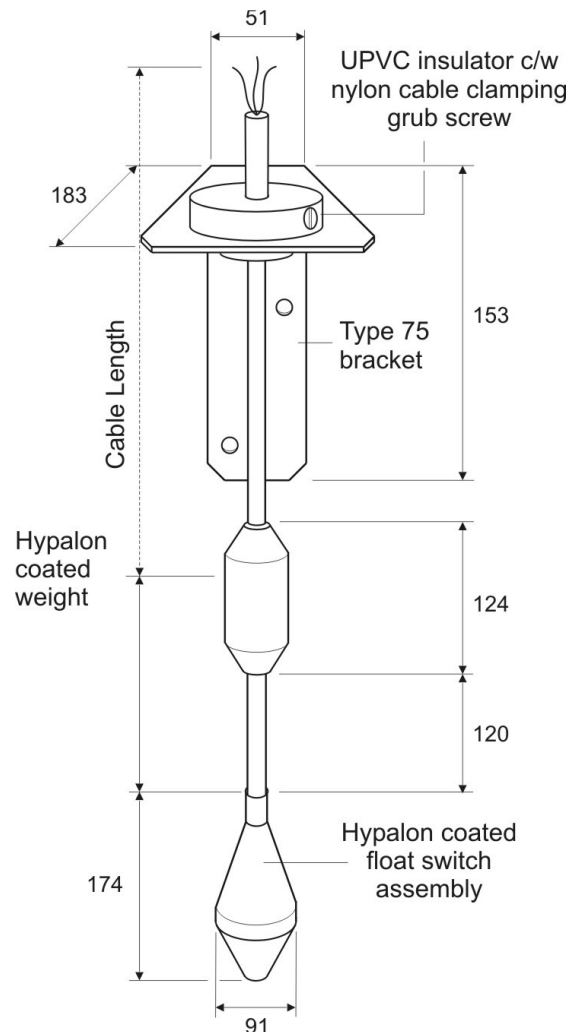

# HAWKER LEVEL CONTROL SYSTEMS

## TYPE HFL2 Float operated level control

- Ecologically friendly contains no lead or mercury.
- ATEX approved option.
- Float housing moulded in Hypalon (chlorosulphonated polyethylene).
- Available in 5m, 10m, or 25m cable lengths with actuating weight fitted.
- Simple to install and easy to remove for cleaning.
- Suitable for all liquids which do not attack the float material, e.g. chemicals and aggressive liquids with S G's between 0.8 and 1.3.



### Operating principle

The float is suspended from its cable just below the surface of the liquid so that wave effect is negligible. When the liquid reaches or leaves the float, it tilts and operates its mechanical switch, the angle of the operation being  $45^{\circ}$ , this can stop or start a pump or operate an alarm.

Two floats are required for control between two levels. They are provided with external ballast to ensure correct tilt operation in any direction.

Although the floats are designed to switch mains, it is preferable to interpose a low voltage power supply with a relay such as the Hawker 118 or AC1 wall-mounting units, which switch 5 amps.

A rolling ball and its axially mounted line with the ballast weight control the single pole double throw micro switch. As the switch tilts contact are either made or broken to start or stop pump etc.

If excessive turbulence is expected the cable should be either supported or clipped to the side of the vessel.



# HAWKER

# TECHNICAL SPECIFICATION

## Technical Data

Float chamber and weight: Hypalon coated (chlorosulphonated polyethylene)

Cable: 3 X 0.75mm<sup>2</sup> C.P.E. sheathed (chlorinated polyethylene synthetic rubber).

Contact rating: 5A @ 250V 50Hz (non inductive) use an interposing level controller to comply with health and safety regulations.

Max submerged depth: 20 metres.

Max operating temp: 70°C.

S.G. of liquid: 0.8 to 1.3

Weight: 1.3Kg/5m, 1.8Kg/10m, 3.2Kg/25m

Chemical resistance: Full information on the chemical resistance of the HFL2 float switch will be given on request.

## Ordering Information

HFL2/05m: 5 metre cable  
 HFL2/10m: 10 metre cable  
 HFL2/25m: 25 metre cable (other cable lengths are available on request).  
 HFL2/IS: Cat 2G ATEX approved option.

Optional mounting brackets: Type 75 galvanised MS bracket with UPVC cable clamp  
 Type 75/SS stainless steel bracket with UPVC cable clamp.

## Connection Diagrams

Hawker Electronics Level Controller Connections

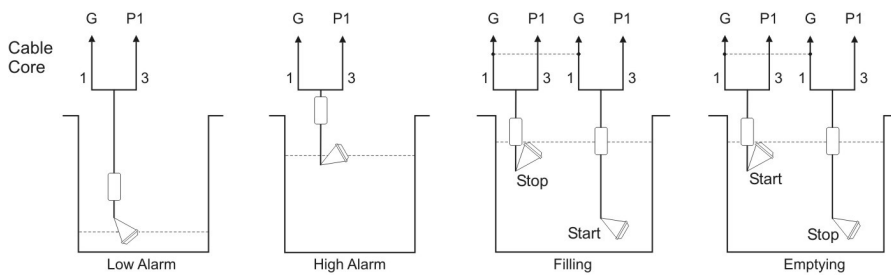

Cable Core Colour		Single Float		Dual Float			
		Low Alarm	High Alarm	Filling	Emptying		
Brown (Common)	1	✓	✓	✓	✓	✓	✓
Blue	2						
Black	3	✓	✓	✓	✓	✓	✓

*This product has been designed and complies to the relevant standards as listed in its certificate of conformity the installer/user must ensure compliance.  
 The crossed-out bin symbol, placed on the product, reminds you of the need to dispose of the product correctly at the end of its life.  
 Because of continuing development we reserve the right to change the specifications without notice*

## HAWKER ELECTRONICS LTD.

57 The Avenue,  
 Rubery Industrial Estate,  
 Birmingham B45 9AL, ENGLAND  
 Telephone: +44 (0)121-453-8911 Fax: +44(0)121-453-3777  
 email: info@hawker-electronics.co.uk www.hawker-electronics.co.uk



FM 10000

