

FLEXICAP

Continuous Capacitance Level Indication & Control System

Installation & Setting up Instructions

The FLEXICAP Probes
are used in conjunction with
one of the following control units

FLEXILEVEL 1 is an Analogue unit

FLEXILEVEL 2 is a Digital unit

See also the Setting up Instructions
Supplied with these Controllers

HAWKER ELECTRONICS LTD

57, The Avenue,
Rubery Industrial Estate,
Birmingham, B45 9AL, ENGLAND.
Tel: +44(0)121 453 8911
Fax: +44(0)121 453 3777
email: info@hawker-electronics.co.uk
web: www.hawker-electronics.co.uk



FM 10000

Mar 2002
Issue B

O&M 45

This product has been designed and complies to the relevant standards as listed in its certificate of conformity. The installer/user must ensure system compliance

FLEXICAP

Continuous Level Indication and Control System
INSTALLATION AND SETTING UP INSTRUCTIONS

(For Principle of operation see page 5)

1.0 GENERAL

The system comprises:-

- 1.1 A 'Flexicap' electrode mounted vertically in the vessel whose level is to be monitored
- 1.2 Flexicap transmitter which plugs into the electrode
- 1.3 A 'Flexilevel' control unit connected to the probe by two core screened instrument cable.
There are six types of electrode:-

	<u>Type</u>
1.4 Bare rod for non-conducting liquids such as oils etc. (Where K is greater than 5)	FCP1
1.5 Insulated rod for conducting liquids such as water etc.	FCP2
1.6 Concentric tube for non-conducting liquids such as oil etc.	FCP3
1.7 Concentric tube for conducting liquids with inner electrode insulated.	FCP4
1.8 Insulated cable for conducting liquids	FCP 201
1.9 Non-insulated cable for non-conducting liquids	FCP 101

THE ELECTRODE

- 1.10 The electrode has been carefully packed . If damage is discovered please report it to us right away.
- 1.11 Bare rod and concentric electrodes may have their length altered by cutting.
- 1.12 Insulated electrodes must not be cut.
- 1.13 A stainless steel bracket is available to mount the electrode onto a flat surface. See drawing No 2657.
- 1.14 In turbulent conditions a metal bracket connected to earth may be used to steady the electrode (see drg no 2657). Alternatively, we can supply a plastic still well.

2.0 INSTALLATION

2.1 Mount the electrodes vertically at the top of the vessel. The 1" B.S.P. union which is integral with the plastic termination head, must be earthed to the liquid.

In metallic vessels (which are earthed) this may be achieved through the mounting bracket which is connected to the earthed link.

In Non-Metallic vessels it is necessary to earth the liquid,. If this is not possible or proves to be ineffective, it may be necessary to provide a separate earth electrode .

Mount the electrode away from tank inputs. If there is excessive turbulence, a stand pipe may be necessary.

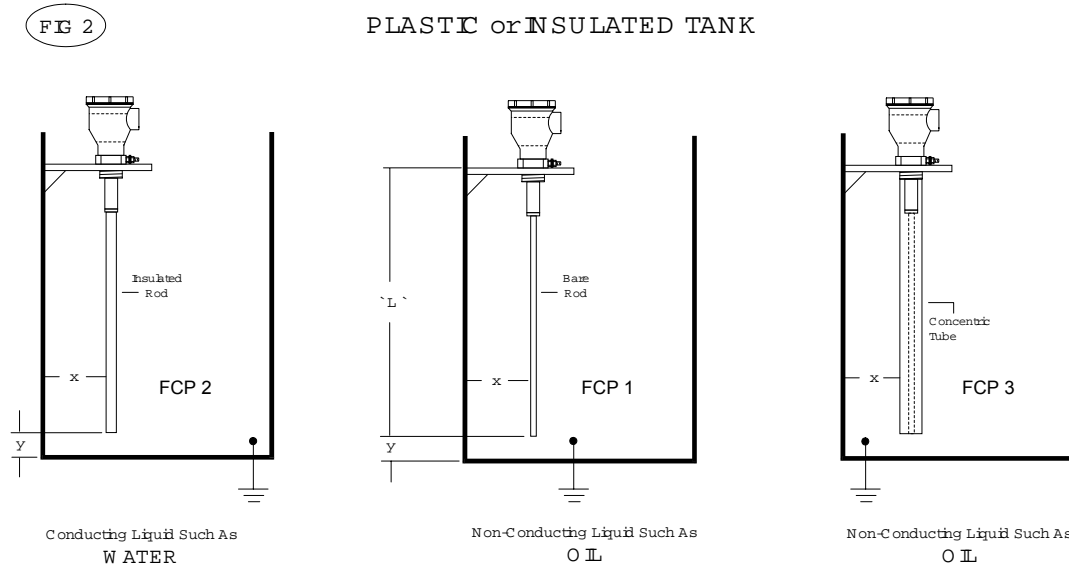
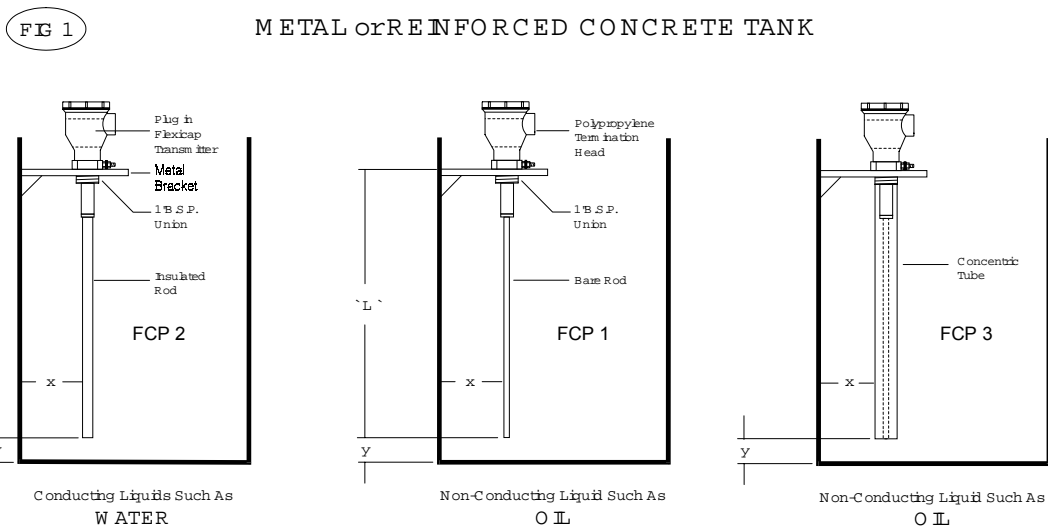

Liquids must be Earthed

- 2.2 Having installed the probes in their respective tanks, connect to Flexicap transmitter in the top of the probe to the Flexilevel controller. Flexilevel 1 is an Analogue type, and Flexilevel 2 is a Digital type and instructions are supplied for each one. Ensure the cable is well sealed into the probe termination head with a suitable cable gland. Earth the screened cable at the Flexilevel controller end only, using the extra terminal provided.
- 2.3 Fix the Flexilevel controller to the wall using M4 screws and connect it to the mains supply (either 230V or 110V, 50Hz) preferably through an isolator
- 2.4 Connect the relay voltage free connects (either NO or NC) to contactors for latching pump control or to the alarm function (where contactors are used, it is advisable to fit a suppression circuit to prevent the induced back EMF damaging the PCB mounted relays.)
- 2.5 The Flexilevel controllers should then be set up as per the instructions supplied with them.
- 2.6 Ensure that a Multi Meter is available for setting up.

CONNECTION DIAGRAM for FLEXICAP to

FXL1

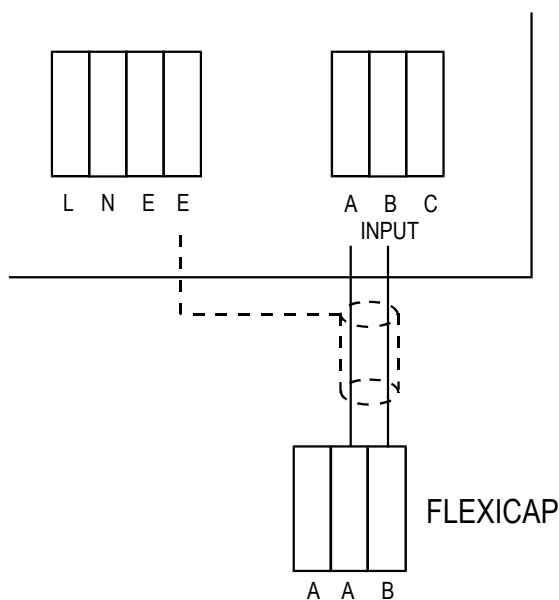

FXL2

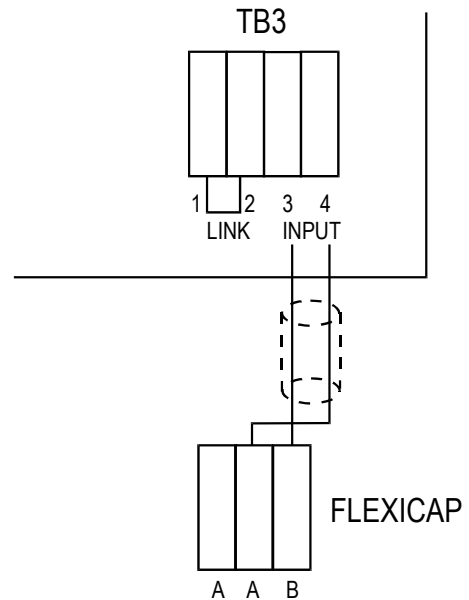

Possible causes of spurious results:-

- 3.1 'Wet coating' due to rag, paper or weed wrapping round the electrode or forming a coating on it.
- 3.2 Viscous products clinging to the electrode. This may sometimes be overcome by using P.T.F.E. coated electrodes.
- 3.3 Fluids with low conductivity (such as distilled water) where variations in the conductivity and temperature can be problematical.
- 3.4 Acids having varying water content and where the conductivity and temperature varies.
- 3.5 Foam if dense, which can coat the electrodes as in (5.1) above.
- 3.6 Note that the presence of steam and condensate are not usually problems.

System does not work:-

- 3.7 Check power input to the Flexilevel.
- 3.8 Check continuity of cables between Flexicap and Flexilevel and that all connections are good.
- 3.9 Unplug the transmitter from the Flexicap electrode. Check that the output across terminals 'A' and 'B' is approximately 28-30V D.C.
- 3.10 Measure the current between the 'B' terminals of the Flexilevel 1 and the transmitter. This should be between 1.5mA and 3mA.
- 3.11 Connect a 100pF capacitor between terminals 'A' of the transmitter and its jack plug. Check the current should have increased to between 18 and 22mA

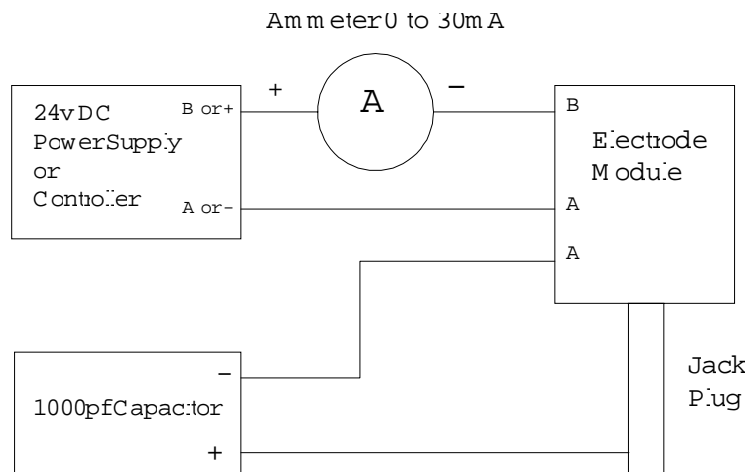

4.0 PRINCIPLE OF OPERATION

- 4.1 The electrode in the 'Flexicap' system represents a capacitor and the small change in its capacitance with varying level is used to produce a milliamp output which is proportional to level. This is registered in the 'Flexilevel' control unit.
- 4.2 A capacitor consists of two metal plates insulated from each other and spaced apart. The insulating material between the plates is called the dielectric, even if this is just air or vacuum.

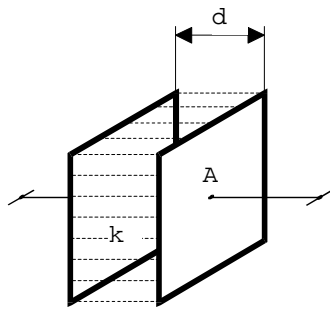

The electrical capacitance C of a capacitor is the amount of electric charge it can store and this depends on three items

- 3) The value of the Dielectric Constant K of the insulation between the plates.
- 4) The area of the plates A
- 5) The distances between the plates d

and the relationship is expressed by $C = K A/d$

The greater the value of K and A the greater the capacitance.
The greater the value of d the smaller the capacitance.

For accurate and stable results, the greatest capacitance change possible is required.

Non electrically conducting products such as oil, diesel fuel, hydrocarbon etc. rely on the dielectric constant, and the higher the value of K , the greater the capacitance change.

Electrically conducting products such as water and many acids rely on the area of the plates. To prevent the capacitor plates being short circuited, a fully insulated electrode must be used.

Some examples of dielectric constant are as follows:-

Conducting liquids : Water = average $K = 80$
 Sulphur Dioxide = 17.6

Non-conducting liquids: Air, Steam, Gases, Vacuum = approx 1
 Glycerine = 47.