

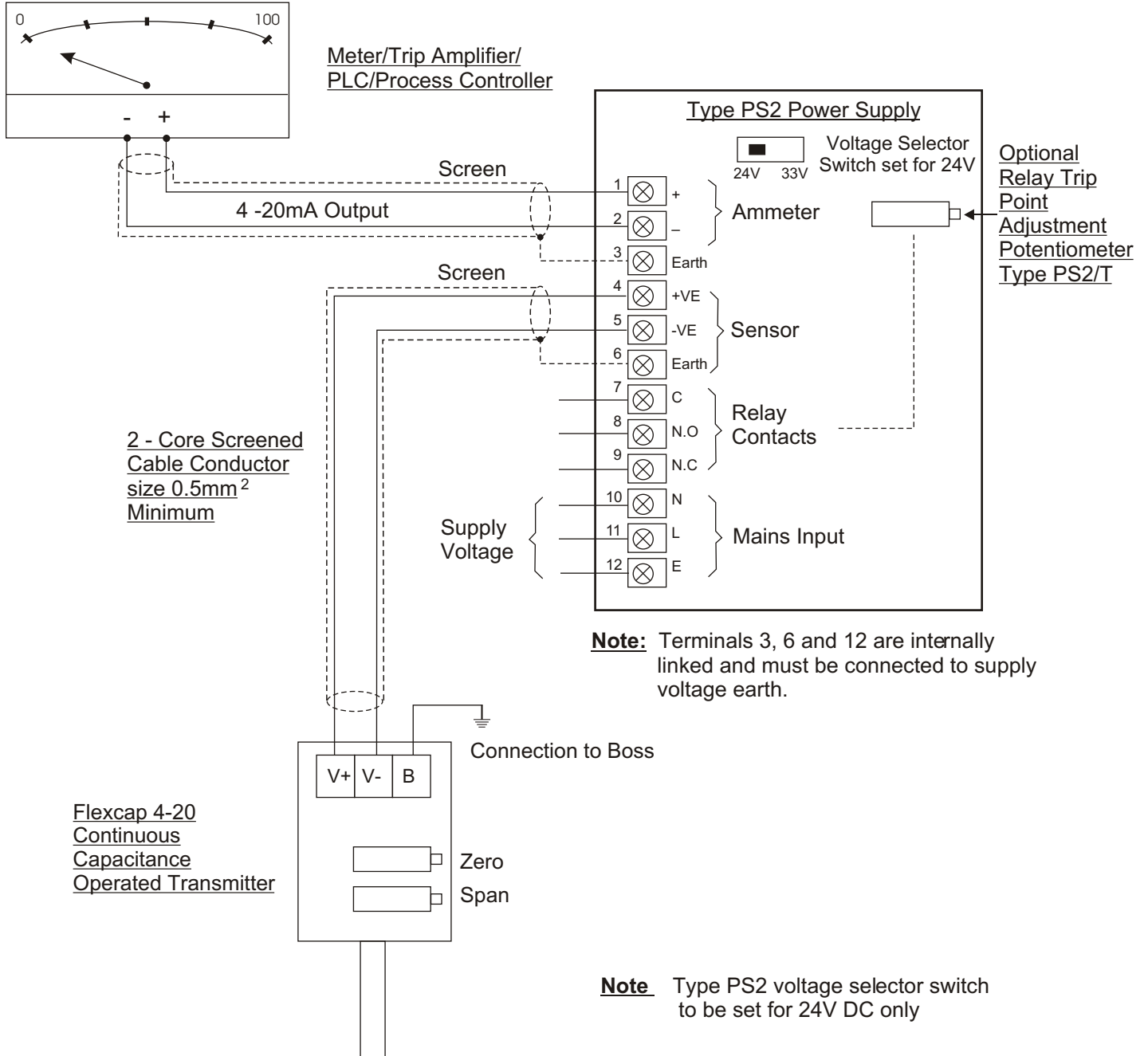

FLEXICAP 4 -20 TRANSMITTER / PS2

Wiring diagram for Flexicap 4 -20 continuous capacitance level transmitter used with type PS2 power supply, to be read in conjunction with type Flexicap 4-20 and PS2 installation and setting-up instructions



This product has been designed and complies to the relevant standards as listed in its certificate of conformity. The installer/user must ensure system compliance
Because of continuing development we reserve the right to change the specification without notice

HAWKER ELECTRONICS LTD

57, The Avenue,
Rubery Industrial Estate,
Birmingham, B45 9AL, England
Telephone :+44(0)121-453-8911 Fax: +44(0)121-453-3777
E.mail: info@hawker-electronics.co.uk



FM 10000



W D 55
B.D. D695.cdr
Issue B
Feb 02