

Installation and Setting up Instructions for the 990 Signal Conditioning Instrument

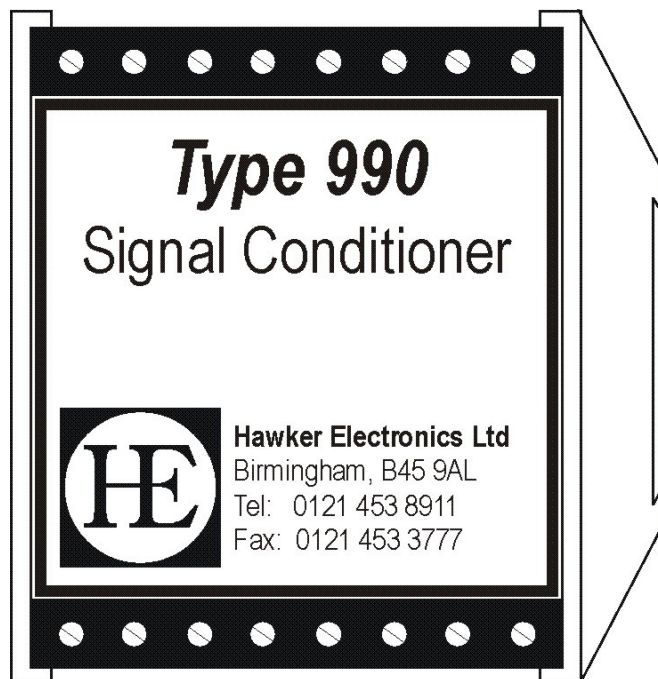

Hawker Electronics Limited
57 The Avenue,
Rubery Industrial Estate,
Tel: +44(0)121-453-8911 Fax: +44(0)121-453-3777
www.hawker-electronics.co.uk
e-mail: info@hawker-electronics.co.uk

O&M 74
Issue B
April 05



FM 10000

Contents	Page
1.0 Overview.....	3
2.0 Installation	4
2.1 Electrical connections	4
2.2 Cable selection	4
2.3 Electrical connection diagrams	5
2.3.1 Lower terminal Block	5
2.3.2 Upper terminal Block	6
3.0 Configuring the 990	7
3.1 Vessel high and low levels	7
3.2 Forward or Reverse LCD	8
3.3 Forward or Reverse acting current/voltage	8
3.4 Calibration table	10
3.5 Run mode	10
3.6 Internal precision simulator	10
3.7 Programming the unit	11
4.0 The 990 electrical output signals	12
4.1 Analogue current and voltage output	12
4.2 Digital communications output, RS232.....	12
5.0 Technical specification	14
6.0 Declaration of conformity.....	15

1.0 Overview

The 990 is a signal processing unit that takes a signal from an input device, normally situated in a vessel, and provides an analogue and digital re-transmission output which is generally used for control or alarm applications.

The unit accepts signals from a wide range of remote instruments, including the Hawker Flexicap and SondaLoop or other transducers and transmitters. After user calibration the input signal is displayed on its internal LCD as a percentage in the range of 0 to 100.0. The user may calibrate the LCD full-scale percentage over any part of the vessel. The retransmission output provides an analogue current and voltage proportional to the user calibrated input, as well as a digital transmission communications link via RS232, which provides many extra functions when used with Hawker software. Other special functions can be programmed by the user, such as a reverse acting display or reverse acting retransmission output, both of which are accessed through the 990 menus.

The 990 provides power for transducers or loop-powered transmitters and can accept a direct signal input for a transmitter with an external power supply, see connection drawings.

The 990 can be set to run in “simulator mode”, where it effectively becomes a precision current and voltage source, this is useful for calibration during commissioning, and for diagnostic purposes.

Setting up is simple, using the two pushbuttons and the LCD on the front of the unit provides very accurate and fast commissioning.

- **Simple installation and calibration**
- **Any part of the vessel may be spanned by the user**
- **Analogue and digital communications output**
- **Output retransmit and display can be configured as ‘Reverse Acting’**
- **Digital communication RS232 may be linked to a computer**
- **High degree of accuracy, linearity and repeatability excellent drift with temperature and time**
- **Sufficient loop drive capabilities for realistic cable and line resistance**
- **Isolation between input and output**
- **Small, compact, low power device**
- **Available with many input power supply options**
- **100% compatibility with Hawker listed products**

2.0 Installation

Installation, connection and commissioning of this instrument should be carried out by competent persons who are familiar with the relevant local regulations and codes of practise.

The unit is housed in a polycarbonate enclosure weather proof to IP20, and should be installed in a dry dust free environment usually inside a control panel or similar, which provides a greater degree of ingress and mechanical protection. It can be attached to snap on/off DIN rail (DIN 46 277) or fastened to a suitable surface using two screws or bolts in the mounting holes provided on the top and bottom of the box. The mounting should be carried out so that it provides a sound fixing for the units weight and dimensions, an air gap of at least 20mm should be allowed around its perimeter for ventilation purposes. Always mount so that the power input supply and output signals are on the bottom, this ensures the LCD will be correctly orientated.

Virtually no maintenance is required once installed and calibrated, only periodic testing depending upon application etc. Cleaning is not normally necessary but can be carried out (once the power is disconnected) using a mild detergent on a moist cloth.

2.1 Electrical connections

Terminal blocks are provided on the top and bottom of the unit for all electrical connections, the captive self-locking screws, accepts up to a 4mm² conductor. Before switching on the apparatus ensure the supply voltage and other input and output specifications are correct, this can be established by checking the label on the side of the unit.

2.2 Cable selection

All cables require adequate mechanical protection and should be suitably rated to carry the particular voltages and currents listed in the technical specification. High voltage cables should have a suitable means of isolation and not be run alongside signal cables. Installations in industrial or noisy environments should always use high quality screened cables for the input and output signals, which are rated so as not to degrade the electrical signals i.e. volt drop and capacitance. Digital cables should not be run in a multi-core along with analogue signals, unless individually screened. The RS232 cable length is usually limited to around 25m but tests have shown using the cable above it is possible to exceed 100m, this of course being application dependant. Below are some examples of commonly used cables.

Power input cables	single cores in a conduit or trunking, or multi-core armoured.
Input signal cables Sondaloop, Flexicap Pressure transmitter, transducer	comes with multicore shielded Instrumentation cable attached.

Output signal cables

single cores in a conduit or trunking or multi-core armoured. Preferred type is shielded Instrumentation cable and twisted paired.

RS232

Shielded twisted paired cable suitable for RS232 such as Belden 9501

The lower terminal block has two connections marked “E” these are internally linked via the printed circuit board; the installer should connect one of these to mains earth, this earth is for safety and not product functionality.

2.3 Electrical connection diagrams

2.3.1 Lower terminal block

The Lower terminal block, Fig 2.1 contains the connections for:

Power Input Incoming power supply. It is important to check the specification label to confirm the supply requirements i.e. 240VAC, 110VAC/24VAC or 24DC. The terminal block label is also different for ac and dc versions, Fig 2.1(a) shows the AC label and Fig 2.1(b) the DC label. This voltage is factory set.

Voltage Output The retransmission voltage output. This is a continuous output voltage signal over the calibrated input signal of 0 to 100%. This can be connected to external equipment such as voltmeters, voltage driven displays or PLC's.

Current Output The retransmission current output. This is a continuous output current signal over the calibrated input of 0 to 100%. External equipment such as ammeters, current driven displays or PLC's are connected in series.

Fig 2.1(a) Power input using ac

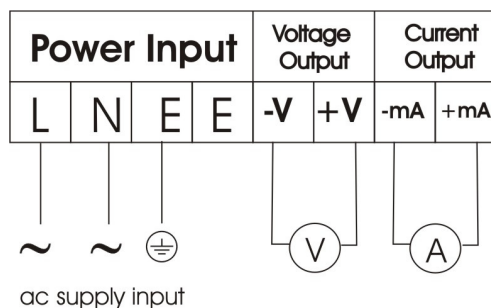
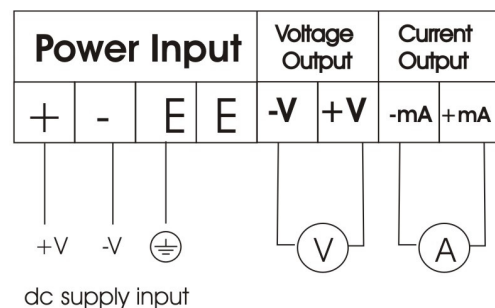

Fig 2.1(b) Power input using dc



2.3.2 Upper terminal block

The upper terminal block contains the connections for the input transducer/transmitter and the digital output:

Input Transducer (mV)

A transducer giving a mV output should be connected as shown in Fig 2.2. These types of devices are generally pressure transducers mounted in the vessel.

Input Transmitter (mA)

Transmitters giving a mA current output should be connected as shown in Fig 2.3 and Fig 2.5. When using a pressure transmitter the screen should be terminated to the 0V connection. If using a SondaLoop or Flexicap, Fig 2.5, the screen wire is not available and therefore not connected. The user must fit a wire link as shown across the -S input and 0V input as shown for both configurations.

Pressure Transducer / mV Input (Fig 2.2)

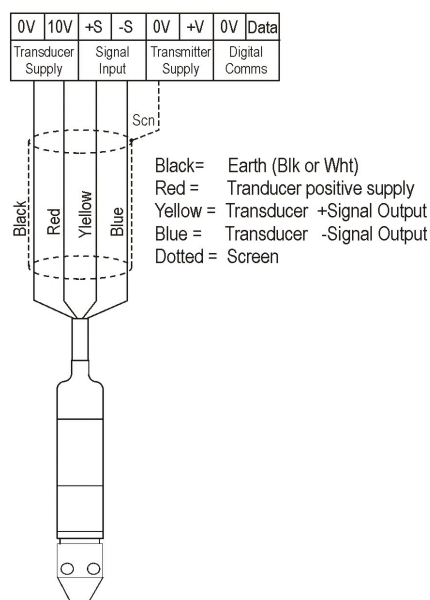

Pressure Transmitter /mA (Fig 2.3)

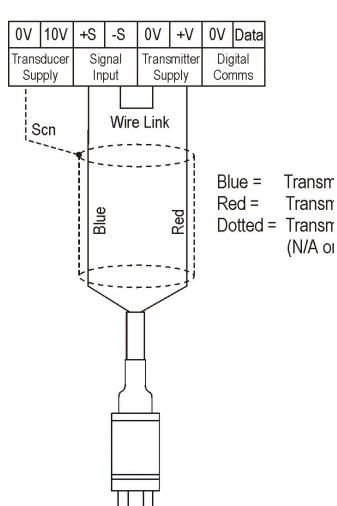

Flexicap and Sondaloop (Fig 2.5))

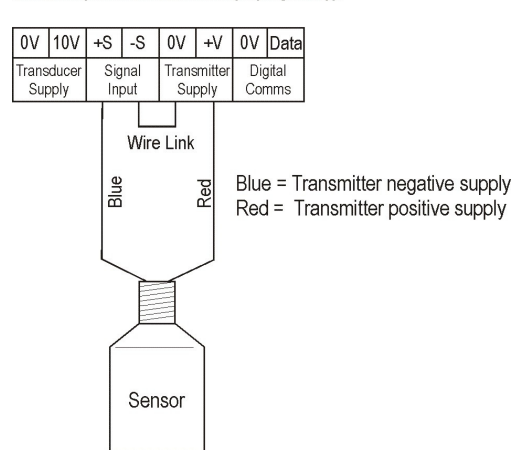

Digital Communications (Fig 2.4)

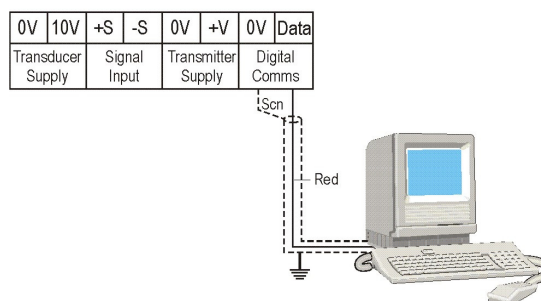

Digital output

The Upper terminal block also contains the terminations for the digital communications connection to a computer with an RS232 serial input card, Fig 2.4. See the digital output section regarding earth isolation and the digital signal.

3.0 Configuring the 990 options

The 990 has several options that the user must program, a description of these is given in the following sections. The user vessel high and low levels need to be calibrated first this is explained in section 3.1, followed by application specific options.

3.1 Vessel high and low levels

The most important settings are the user high and low input points, referred to as THi & TLo on the 990 LCD menus. These points correspond to the high and low levels in the vessel. The points can be set over any part of the vessel (Fig 3.1) the only requirement is that the low input signal must be less than the high input signal. Once programmed the input signal between the TLo and THi points are rescaled internally by the 990 to give an output in the range of 0 to 100.0 % or 100 to 0%, depending on other options set by the user.

This can be achieved in any one of three ways

1. Empty and fill the vessel and store the attained values from the input device at each point, this is the preferred method
2. If the vessel can't be emptied or filled calculate the values then input to the 990 using a current or voltage source
3. Alternatively if the user provides the input and output data values the instrument can be calibrated at our works prior to despatch

The programmed values are stored in non-volatile memory and are automatically recovered if the power fails, they can be re-programmed by repeating the procedure.

Fig 3.1 show examples of different input spanning options using a current input. The 990 display, and output current and voltage will be spanned over the THi and TLo settings.

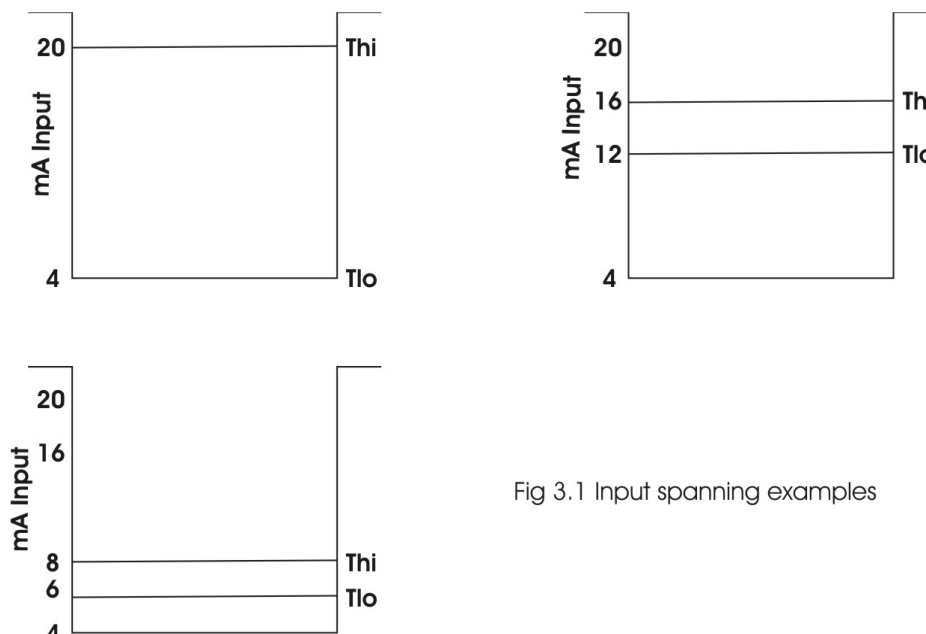

Fig 3.1 Input spanning examples

3.2 ‘Forward’ or ‘Reverse’ acting LCD

The following sections deal with application specific requirements, the vessel does **not** need to be emptied or filled in order set these options; only an understanding of the application is necessary.

Selecting a *Forward LCD* displays the input percentage as a forward acting value on the 990’s liquid crystal display. Where 0% is equal to the vessel low level and 100% is equal to the vessel high level. This is the normal display used for measuring the liquid levels in a vessel.

Selecting *Reverse acting LCD* displays the input percentage as a reverse acting value on the units liquid crystal display. Where 0% is equal to the vessel high level and 100% is equal to the vessel low level. This is used to display the amount by which a vessel is unfilled sometimes referred to as “ullage”. This is useful where the user needs to know the unfilled air space available, maybe for more liquid, gas, expansion or leakage.

Fig 3.2 shows the four possible relationships between the user set parameters and the 990 LCD and re-transmission outputs. A 0-100 mV input is used in the example as it can be easily translated to 0-100% for any input device; it is also shown as spanned over an empty and full tank.

3.3 ‘Forward’ or ‘Reverse’ acting current/voltage

Selecting a *Forward current* sets the retransmission outputs to be at minimum when the input signal is at minimum and at maximum when the input signal is at maximum, i.e. with the tank empty the output is 4mA and with the tank full the output is 20mA.

Selecting a *Reverse current* sets the retransmission outputs to be at maximum when the input signal is at minimum and at minimum when the input signal is at maximum, i.e. with the tank empty the output is 20mA and with the tank full the output is 4mA.

Note: - The retransmit acting output is dependant upon the input signal and not the LCD reading.

Fig 3.2

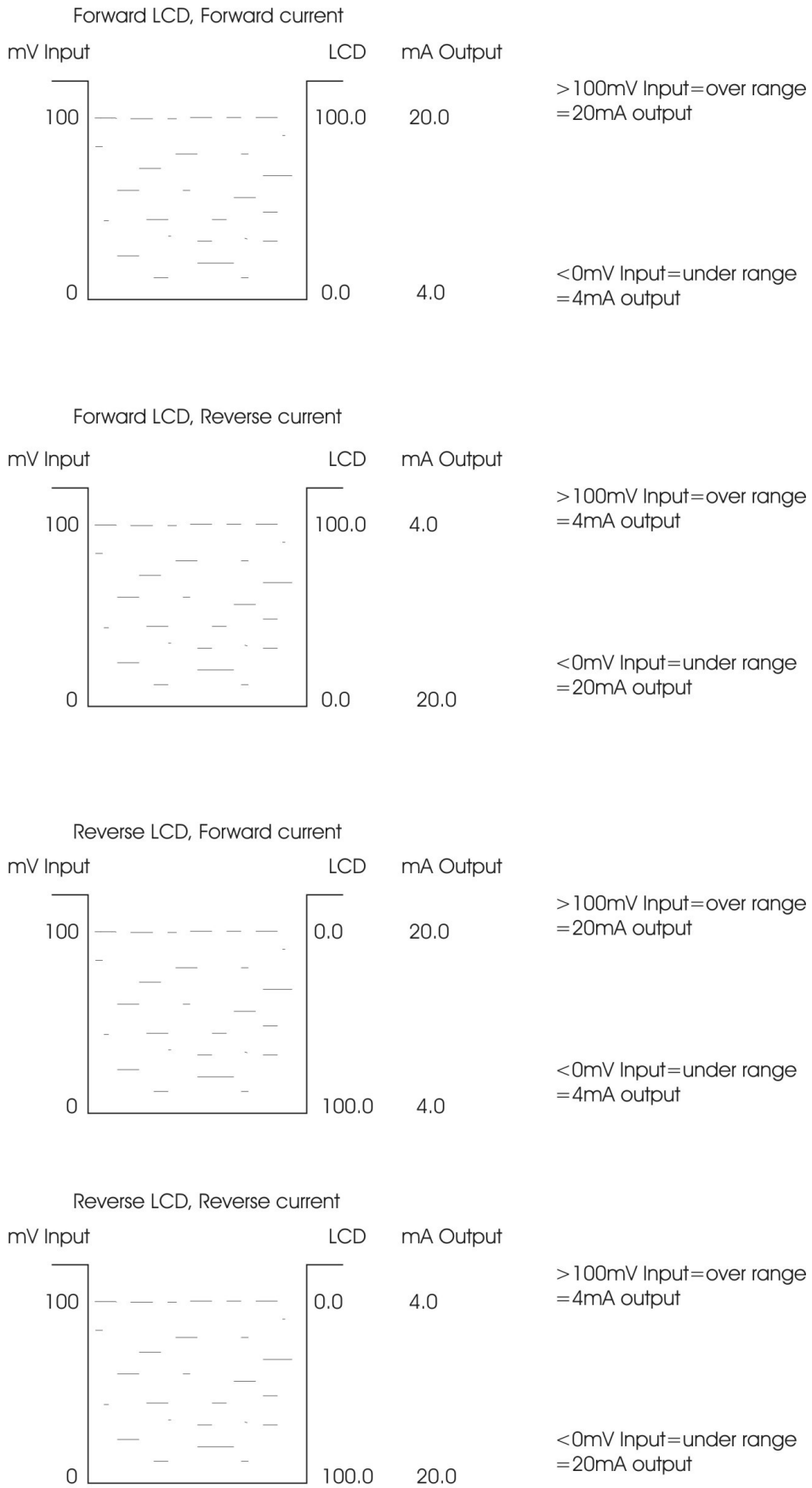

Fig 3.2 Input and output LCD/current/voltage relationship

3.4 Calibration table

It is recommended that after calibration the details are logged in the space provided below. This may be useful if recalibration is needed or the values are accidentally overwritten.

Specification	Example data	Real application data
Input device range	0-10psi I/P, 0-100mV OP	
Tank range	0-3.52m water depth,0-5psi	
990 low Input TLo	0m = 0mV	
990 high Input THi	3.52m = 50mV	
990 LCD	Forward acting	
990 re-transmission	Forward acting	
Notes	This uses a pressure transducer giving a mV output. Location is Water Tank 1.	

3.5 Run mode

This is indicated by a flashing decimal point. In this mode the real time signal from the input device is being monitored and processed.

3.6 Internal precision simulator

The unit has an inbuilt precision simulator that can be used for commissioning and diagnostic purposes. Simulate mode is indicated by a stationary decimal point on the LCD. When in this mode the unit gives a current and voltage output via the retransmit terminals. The user can increment or decrement the output by pressing the keys on the front of the unit. To enter simulation mode from Run Mode press the “E” key, do not release it, then press the “M” key for approximately 5 seconds. The unit will display ‘Son’ (Simulator On), ‘done’ (done) and then 50.0 this will now output 50% of the output span. Use the “M” and “E” keys to increment the LCD reading and output signal in 0.1% steps.

If in forward acting output current mode the “E” key will increment the output, if in reverse acting output mode the “M” key will decrement the output.

To exit simulator mode press both “M” and “E” keys simultaneously the display shows ‘Soff’ (simulator off) and then done. The unit returns to run mode.

The simulator has an auto off function that disables it approximately 10 minutes after turning it on, this prevents leaving it indefinitely in simulate mode accidentally. It can be re-entered immediately by repeating the normal procedure if necessary.

3.7 Programming the unit

LCD Message “done” Used to acknowledge the unit has accepted a user parameter.

“err” Indicate tank hi and lo input points are reversed

“_” Under range input

“_” Over range input

To get out of the programming mode without altering options repeatedly press the “M” key until the decimal point flashes indicating “RUN” mode.

All keys are press and release unless otherwise stated.

Action	LCD	Operation
To enter programming mode press button “M” for 5 seconds		
1 st Press Button M	TLo	Empty the vessel then press “E” to store the new value, “done”
2 nd Press Button M	THi	Fill the vessel then press “E” to store the new value, “done”
3 rd Press Button M	FLcd/RLcd	Displays current setting for Forward or Reverse acting LCD, Press “E” to toggle & store, “done”
4 th Press Button M	Rcur/Fcur	Forward or Reverse acting retransmission output Press “E” to toggle & store, “done”
5 th Press Button M	xxx.x	Return to Run mode A flashing decimal point indicates RUN mode.
Button “E” & then “M” both held for 5seconds	Son	Turns simulator function on, varying 0-100% output.
Button “E” Button “M”		Ramps current up Ramps current down (in forward acting mode)
Button “E” & “M” pressed simultaneously	Soff	Turn simulator function off

4.0 The 990 electrical output signals

4.1 Analogue current and voltage output

An analogue current output is available that can be used to drive external equipment such as valves, solenoids or PLC's. This re-transmission current allows long cable lengths and offers superior noise immunity over the voltage and digital signal outputs. The resistance in the current loop should not exceed that listed in the technical specifications. If the output current is not being used a link should be fitted across the +mA and -mA terminals.

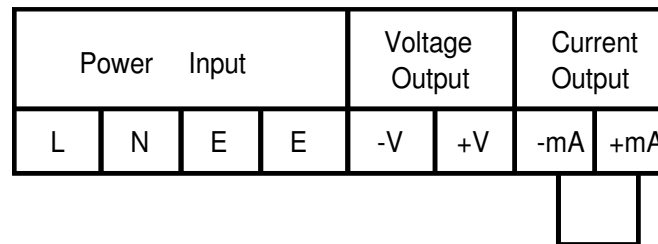

The analogue voltage output may also be used to drive external equipment but is normally only used for short runs such as other instruments located in a local panel. The load resistance should be equal to or greater than that listed in the technical specifications. If the output voltage is not being used it should be left open circuit (do not link).

The analogue current and voltage output signals are electrically isolated from the input signals and the digital output* see Digital Output.

4.2 Digital communication output, RS232

The unit has a digital communication link that transmits data to a personal computer, this offers many extra functions and features, these are detailed in the 990 RS232 PC software manual. Communication is one way, the 990 is the transmitter and the PC the receiver. The data is in an RS232 format, which is acceptable to most personal computers that have a serial port.

Using software provided by Hawker is recommended, the user simply connects the serial connection, configures some user options and runs the program, this can be done in minutes.

For users who wish to use other vendor's software the data format is as follows – ignore this if using the Hawker software.

1 start bit, 8 data bits, 0 parity, 1 stop bit

The data sent mimics the 990 LCD when in Run and Simulation Modes and is sent as a 4 byte packet in the following order.

16 high bits	used for internal diagnostics
8 bits	Low byte of the 990 16-bit LCD value
8 bits	High byte of the 990 16-bit LCD value

The following values are used for error codes, these are transmitted as data bits after the 16 high bits if true.

7d0h	4 & 20mA points reversed
834h	Under Range
898h	Over Range

IMPORTANT

The RS232 output 0V connection is common to the Transducer and Transmitter 0V connection on the 990. This 0V connection may be earthed via the serial connector and PC case, unless the PC serial port is isolated. Plug in isolated cards or adaptor dongles are readily available and should be used if isolation is required.

5.0 Technical specification

Specifications given at 25°C over full input span, rights reserved to change.

Power input	230/110/24Vac $\pm 10\%$ 50Hz 24Vdc $\pm 10\%$
Consumption	5VA max
Signal input	
Current	4-20mA/4-21mA/0-21mA
Voltage	-2 to 100mVdc
Min input span	Not restricted depends on application
Aux. supply	10Vdc @ 10mA for Transducer 24Vdc @ 25mA for Transmitter, (internally limited at 25mA)
Impedance	>1K Ohm voltage 4.7Ohm current
Signal output	4-20mA, 1-5V
Current, Volts	4-21mA, 1-5.25V 0-21mA, 0-5.25V current into 600Ohms, Volts >10K Ohms
Digital	RS232C EIA-232-E Data and Ground
Baud	Fixed 9600Kb
Connection	Serial Port 9/25 Pin COM 1, 2 or 3, user selectable Op system W98/ME/2000/XP req. Microsoft.net framework 25Mb HD space, 32Mb Ram, 233MHz processor or better.
LCD	4 digit, 9mm
Resolution	0.1% LCD, better than 0.1% output current/voltage, FS
Precision	$\pm 0.025\%$
Accuracy error	<0.25% FS
None linearity	0.125% FS
Response time	<0.5S
Hysteresis	0.25%
Warm up time	4 seconds
Op. temp	-10°C to +60°C
Temp drift	<0.1% FS
Enclosure	
Material	Polycarbonate, IP20
Mounting	Snap fastener for Din Rail mounting DIN 46 277
Weight	375g
Terminals	Captive self-locking screws, accepts up to 4mm ² conductor.
Dimensions	55 x 110 x 75mm WxDxH
Extras	
CD-ROM	Hawker 990 Digital Communication Software

DECLARATION OF CONFORMITY

According to the
EMC Directive 89/336EE and Low-Voltage Directive, 73/23/EEC
Including amendments by the CE Marking Directive, 93/68/EEC

Type of equipment: **Signal Conditioner**
Brand name: **900 series**
Type model: **990**
Manufacturer: **Hawker Electronics Ltd.**
Manufacturers Address: **57 The Avenue, Rubery Industrial Estate, Rubery,
Birmingham, B45 9AL. U.K**

Tested to the following harmonised European EMC standards: -

Generic Standards EN50081/2 Using EN55011 Class A limits
EN55011, EN61000-4-4, EN61000-4-2

Additional notes 1.

The following harmonised European standards or technical specifications have been applied: -

*BS EN 61010-1 :2001 Safety requirements for electrical equipment for
measurement, control and laboratory use.*

Additional notes 2.

Indicate below compliance, with reference to the above Directives:

- The product complies with the harmonised European safety standards listed above.(see Additional notes)
- The product complies with good engineering practice in safety matters within the EEA, including parts of the safety standards / specifications listed above.
- We have an internal production control system that ensures compliance between the manufactured products and the technical documentation.

As manufacturer /~~the manufacturer's authorised representative~~ established within the EEA, we declare under our sole responsibility that the equipment follows the provisions/Directives stated above.

Signed  Date..... 20-04-04
John Slevin
Managing Director